

Liquid Crystal Aligning Capability Before and After Washing Process on Various Polyimide Surfaces

논문
12-8-5

Dae-Shik Seo*

Abstract

In this paper, the washing effects on the liquid crystal (LC) aligning capability in nematic liquid crystal (NLC), 4-n-pentyl-4-cyanobiphenyl (5CB), on rubbed polyimide (PI) surface were investigated. The induced optical retardation from washing process on rubbed PI surface is smaller when compared with the non-washing process. The generated pretilt angles in 5CB from the non-washing process on rubbed PI surface are almost the same as that of the rubbed PI surface after washing process. The polar anchoring energy of 5CB on weakly rubbed PI surfaces increased by the washing process. The surface ordering of 5CB for all washing process is larger than that with the non-washing process. Consequently, we suggest that the pretilt angle, anchoring strength, and surface ordering are stabilized due to washing process : LC aligning capability is largely attributed to the washing effects.

Key Words(중요용어) : Nematic liquid crystal(NLC), Polyimide, Rubbing strength, Washing Process, Anchoring strength, Surface ordering

1. INTRODUCTION

Nowadays, twisted nematic (TN) liquid crystal display (LCD) devices are widely utilized for the information displays. Pretilt angle prevents the creation of reverse tilt disclinations in TN-LCD. The generation of pretilt angle in NLC on various alignment layers by unidirectional rubbing has been demonstrated and discussed by many investigators¹⁻⁶. Rubbed polyimide (PI) surfaces have been widely used to align LC molecules.

TN-LCDs have been fabricated by using mechanical rubbing to align LCs, but it generates dusts and electrostatic charges. The thin film transistor (TFT)-LCD and super (S) TN-LCD are damaged by the induced

electrostatic charges produced during rubbing. Previously, Matsuda et al. reported the induced electrostatic charges and pretilt angle generation of NLC on various rubbed PI surface as a function of rubbing strength⁶. In practical fabrication of LCDs, the washing process is used to remove the dust and electrostatic charges after the PI surface are rubbed.

The anchoring energy between the LCs and the alignment layers on treated substrate surfaces has been demonstrated and discussed by many investigators⁷⁻⁹. In a previous work, Seo et al. reported the first measurement of the temperature dependence of the polar (out-of-plane tilt) anchoring strength of weakly rubbed PI surfaces in 5CB¹⁰. Recently, we reported the relationship between the surface order parameter and the polar anchoring energy in NLC on weakly rubbed PI surfaces¹¹. In this paper, we report the washing effects on the pretilt angle generation, the anchoring strength, and the surface ordering in NLC, 5CB, on

* : 숭실대학교 전기공학과

(서울시 동작구 상도 5동 1-1, Fax : 02-817-

7961 E-mail : dsseo@ee.soongsil.ac.kr)

1999년 2월 1일 접수, 1999년 7월 12일 심사완료

various rubbed PI surfaces.

2. EXPERIMENTAL

The molecular structure of the used polymer material is shown in Fig. 1. The PI films were coated on indium-tin-oxide (ITO) coated glass substrates by spin-coating, and were imidized at 250°C for 1 hr. The thickness of PI layers was about 500Å. The PI films were rubbed using a machine equipped with a nylon roller (Y₀-15-N, Yoshikawa Chemical Industries Co., Ltd.). The definition of the rubbing strength (RS) was given in previous papers^{2, 3)}. The rubbed PI surfaces were washed after the rubbing. The following washing materials are used : isopropyl alcohol (IPA), pure water, and freon. The characteristics of washing materials are amphiphilic, hydrophilic, and hydrophobic, respectively. We used the wet method for 20 min. for the washing process.

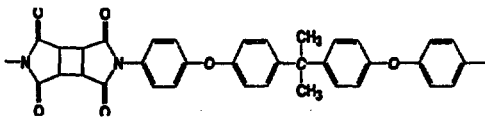

Fig. 1. Chemical structure of the polymer

LC cells were assembled with the antiparallel to rubbing direction. The LC layer thickness was set to 60.0±0.5µm. To measure pretilt angles, we used the crystal rotation method. The measurement of pretilt angle was done at room temperature (22°C). Also, we measured the induced optical retardation on rubbed PI surface with side chain. Next, we measured the anchoring strength by using "high electric-field techniques"^{7, 8)}. Figure 2 shows the measuring system of polar anchoring strength. We measured the optical retardation (R) and the electric capacitance (C) as a function of applied voltage (V) in order to determine

the polar anchoring strength. The optical retardation measurement system consists of a polarizer, an acousto-optic modulator, and an analyzer. The output signal is detected by a photodiode. The electric capacitance of the LC cell is obtained by measuring the out-of-phase component of the current produced by changing the voltage which is applied to the cell. The extrapolation length (de) is determined by using the relationship between the measured values of the electric capacitance and the optical retardation : ^{7, 8)}

$$\frac{R}{R_0} = \frac{I_0}{CV} \cdot \frac{2d_e}{d} \text{ when } V > 6 V_{th} \quad (1)$$

where I₀ is a proportionality constant depending on the LC materials, V and d stand for the applied voltage and LC medium thickness, respectively. R₀ and V_{th} are the optical retardation at V=0 and the threshold voltage, individually.

The polar anchoring energy A is obtained from the following relation :

$$A = \frac{K}{d_s} \quad (2)$$

where K is the effective elastic constant which is given by $K = K_1 \cos^2 \theta_0 + K_3 \sin^2 \theta_0$, where K₁, K₃, and θ₀ stand for the elastic constants of the splay and bend deformations, and the pretilt angle, respectively.

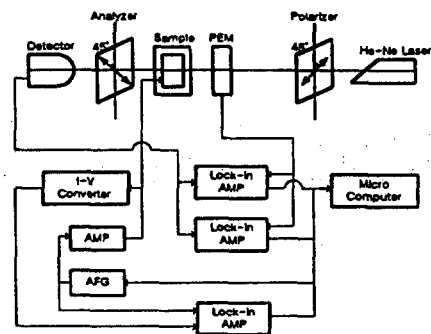

Fig. 2. Measuring system of polar anchoring strength.

We used the measured elastic constants in this work. The surface ordering was obtained by measuring the residual optical retardation induced on the polyimide surface above the nematic-isotropic transition temperature T_c^{12} .

3. RESULTS AND DISCUSSION

Figures 3 (a), (b), and (c) show the generation of pretilt angle in 5CB for non-washing and washing processes on rubbed PI surface as a function of RS. It is shown that the pretilt angles in 5CB for non-washing

process on rubbed PI surfaces are peaked around 100mm and then decrease with increasing RS, and then saturate above the RS=150mm. The obtained pretilt angle of 5CB is stabilized above the RS=150mm. The pretilt angle of 5CB for non-washing process is almost the same as the washing process. It is considered that the generated pretilt angles of 5CB don't vary by the washing process.

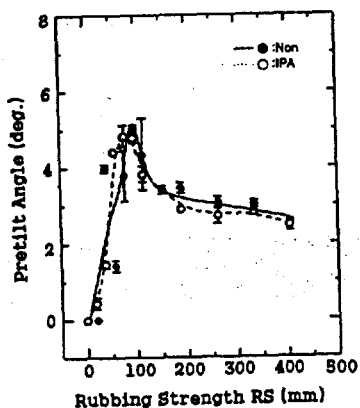

(a) IPA

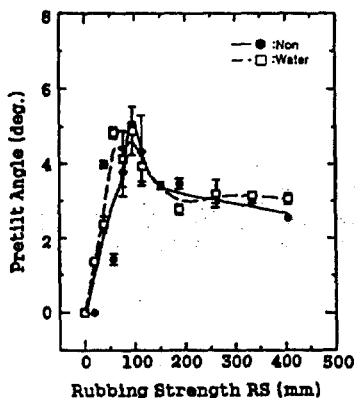

(b) Water

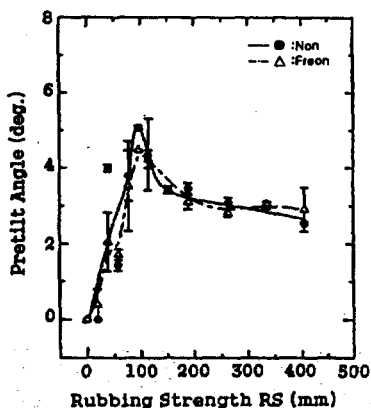

(c) Freon

Fig. 3. Pretilt angle in 5CB for non-washing and washing processes on rubbed PI surfaces as a function of rubbing strength.

Figure 4 shows the induced optical retardation on rubbed PI surface for non-washing and washing processes as a function of RS. The induced optical retardation for non-washing process on rubbed PI surface increases with increasing RS. It is considered that the rubbing process gives rise to an enhanced orientation of polymer chains, thereby creating more anisotropic environment for the LC alignment. The induced optical retardation on rubbed PI surfaces decreased by the washing process, which indicates the washing effects.

The dependence of the rubbing strength of the polar anchoring energy in 5CB for non-washing and washing processes on weakly rubbed PI surface with side chain is shown in Fig. 5. The polar anchoring energy of 5CB for non-washing process on weakly rubbed PI surface is approximately $2 \times 10^{-4} (\text{J}/\text{m}^2)$ at $\text{RS}=57\text{mm}$ and then increases with increasing RS. The anchoring strength of

5CB for weakly rubbed PI surface is strongly attributed to the surface ordering due to the increase of LC aligning capability. Also, the polar anchoring strength of 5CB increased by the washing process : the washing effects are clearly observed. Therefore, the polar anchoring energy on rubbed PI surface increases with increasing surface ordering by washing process.

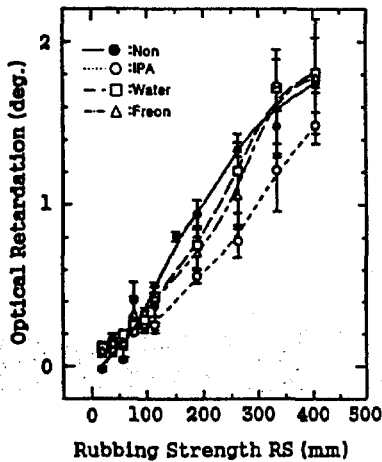

Fig. 4. Induced optical retardation for non-washing and washing processes on rubbed PI surfaces as a function of rubbing strength.

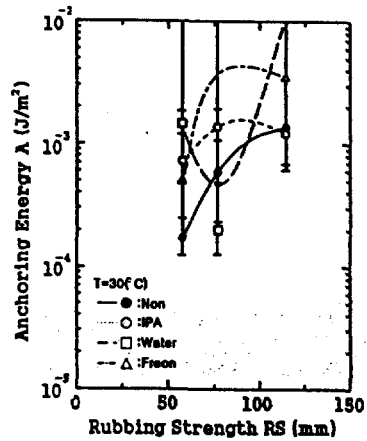
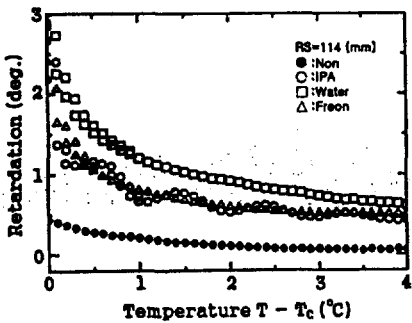
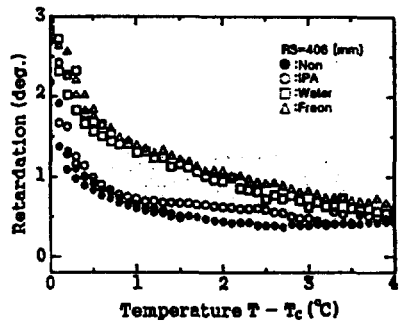

Fig. 5. Polar anchoring energy of 5CB for non-washing and washing processes on rubbed PI surfaces as a function of rubbing strength.



(a) RS=114(mm)



(b) RS=406(mm)

Fig. 6. Optical retardation of 5CB for non-washing and washing processes on rubbed PI surfaces above the clearing temperature.

Figure 6 shows the optical retardation of 5CB for non-washing and washing processes on rubbed PI surface above the clearing temperature. The surface ordering of 5CB for all washing processes on rubbed PI surfaces is larger than the non-washing process. The surface ordering of 5CB increased by washing process on rubbed PI surface. Therefore, the stabilized LC alignment in NLC is strongly attributed to the larger surface ordering. Consequently, we suggest that the pretilt angle, anchoring strength, and surface ordering are stabilized by the washing process : LC alignment capability is strongly attributed to the washing effects.

4. CONCLUSION

In a summary, the generated pretilt angles in 5CB for non-washing process on rubbed PI surface are almost the same as that of the rubbed PI surface with washing process. The polar anchoring energy of the weakly rubbed PI surfaces increased by the washing process. The surface ordering of 5CB for all washing processes is larger than the non-washing process. Consequently, we suggest that the stabilized LC alignment can be attributed to the surface ordering.

References

- [1] T. Sugiyama, S. Kuniyasu, D.-S. Seo, H. Fukuro, and S. Kobayashi, "A simple model for pretilted nematic liquid crystal medium and its torsional surface coupling strength", *Jpn. J. Appl. Phys.*, Vol. 29, pp. 2045-2051, 1990.
- [2] D.-S. Seo, K. Muroi, and S. Kobayashi, "Generation of pretilt angle in nematic liquid crystal, 5CB, media aligned polyimide films prepared by spin-coating and LB techniques : effect of rubbing", *Mol. Cryst. Liq. Cryst.*, Vol. 213, pp. 223-228, 1992.
- [3] D.-S. Seo, S. Kobayashi, and M. Nishikawa, "Study of the pretilt angle for 5CB on rubbed polyimide films containing trifluoromethyl moiety and analysis of the surface atomic concentration of F/C(%) with an electron spectroscopy for chemical analysis", *Appl. Phys. Lett.*, Vol. 61, pp. 2392-2394, 1992.
- [4] B. O. Myrvold, and K. Kondo, "A population distribution model for the alignment of nematic liquid crystals", *Liquid Crystals* 17, pp. 437-455, 1994.
- [5] M. Nishikawa, N. Bessho, T. Natsui, Y. Ohta, N. Yoshida, D.-S. Seo, Y. Iimura, and S. Kobayashi, "A model of the unidirectional alignment accompanying the pretilt angle of a nematic liquid crystal (NLC), 5CB, oriented on rubbed organic-solvent-soluble polyimide film", *Mol. Cryst. Liq. Cryst.*, Vol. 275, pp. 15-25, 1996.
- [6] H. Matsuda, D.-S. Seo, N. Yoshida, K. Fujibayashi, and S. Kobayashi, "Estimation of the static electricity and optical retardation produced by the rubbing polyimide and polyamide films with different fabrics", *Mol. Cryst. Liq. Cryst.*, Vol. 264, pp. 23-28, 1995.
- [7] H. Yokoyama, and H. A. van Sprang, "Novel method for determining the anchoring energy function at a nematic liquid crystal-wall interface from director distortions at high fields", *J. Appl. Phys.*, Vol. 57, pp. 4520-4526, 1985.
- [8] H. Yokoyama, S. Kobayashi, and H. Kamei, "Temperature dependence of the anchoring strength at a nematic liquid crystal-evaporated SiO interface", *J. Appl. Phys.*, Vol. 61, pp. 4501-4518, 1987.
- [9] D.-S. Seo, and S. Kobayashi *Appl. Phys. Lett.*, "Effect of high pretilt angle for anchoring strength in nematic liquid crystal on rubbed polyimide surface containing trifluoromethyl moieties", Vol. 99, pp. 1202-1204, 1995.
- [10] D.-S. Seo, Y. Iimura, and S. Kobayashi, "Temperature dependence of the polar

anchoring strength of weakly rubbed polyimide films for the nematic liquid crystal (5CB)", Appl. Phys. Lett., Vol. 61, pp. 234-246, 1992.

- [11] D.-S. Seo, "Effects of surface order parameter on polar anchoring energy in NLC on weakly rubbed polyimide surface", J.

of Korean Inst. of Electrical and Electronic Eng., Vol. 11, pp. 1128-1132, 1998.

- [12] K. Miyano, "Surface-induced ordering of a liquid crystal in the isotropic phase", J. Chem. Phys., Vol. 71, pp. 4108-4111, 1979.